

PAPER TRAY UNIT (A860/B390) POINT TO POINT DIAGRAM

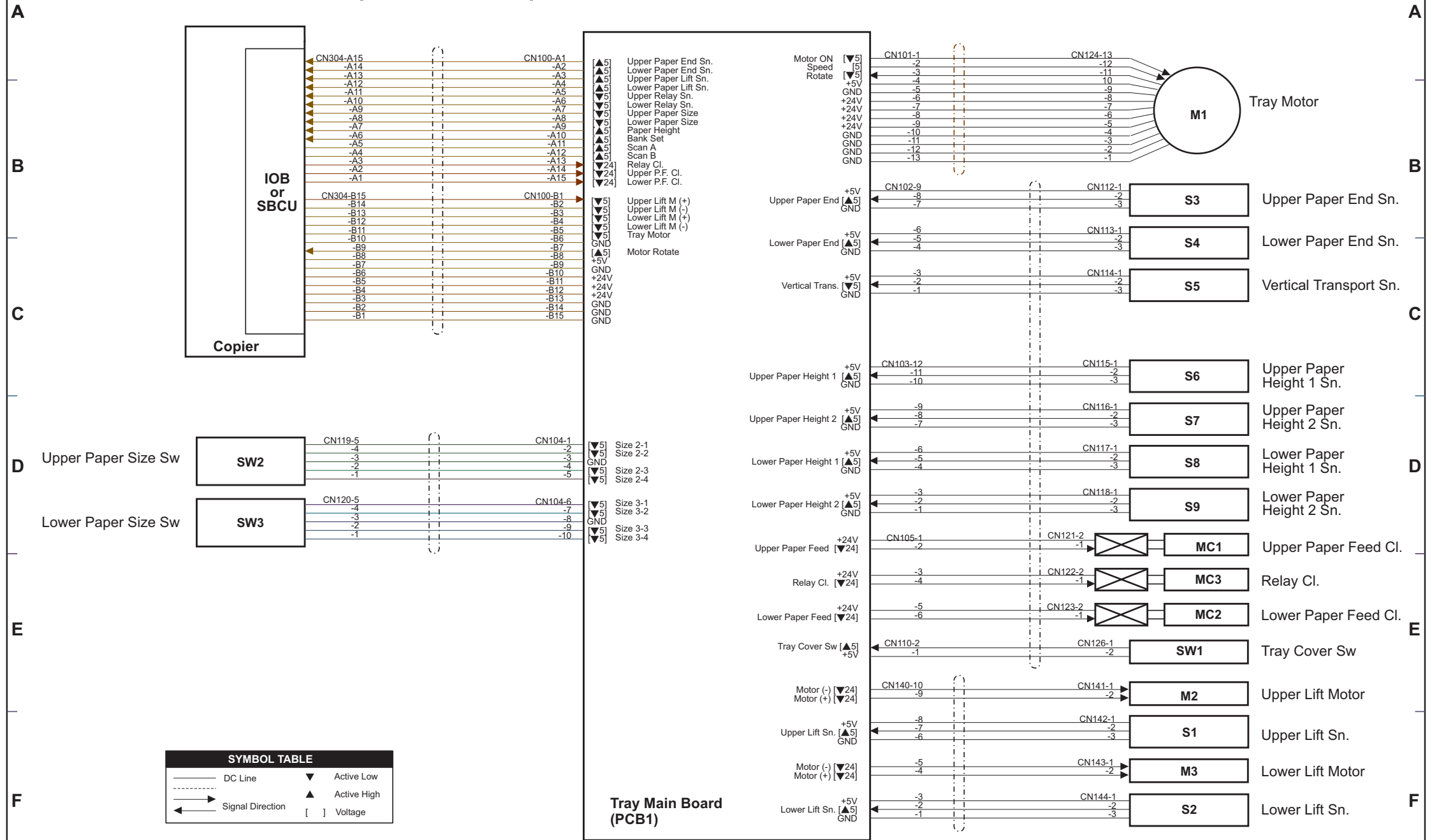

PAPER TRAY UNIT (A860/B390) ELECTRICAL COMPONENT LAYOUT

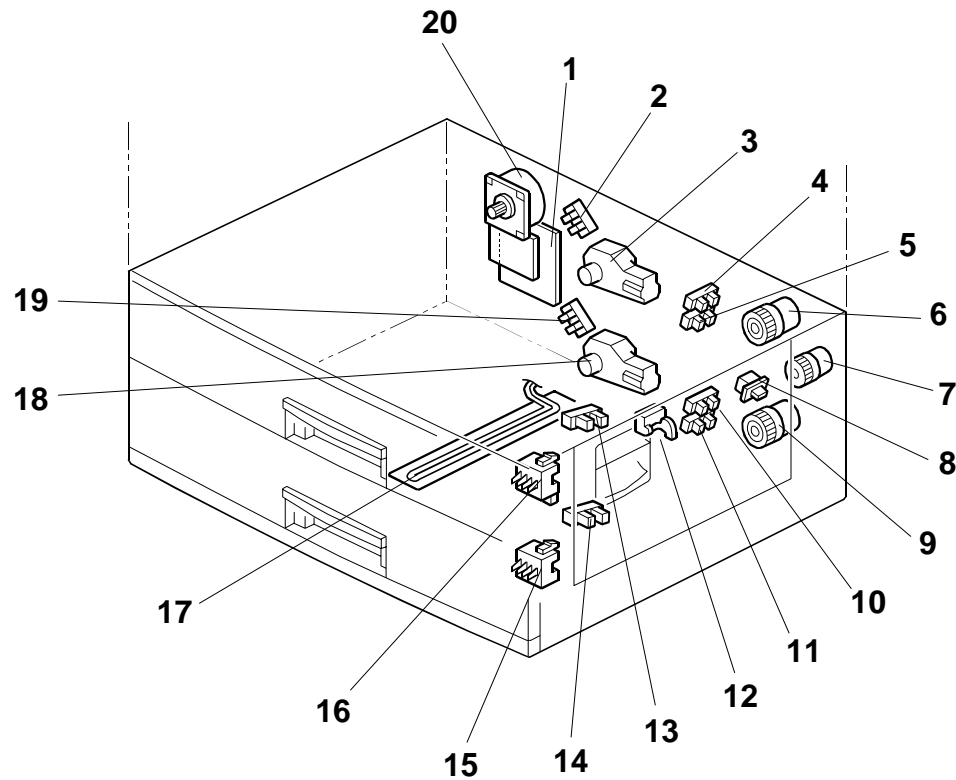

Symbol	Name	Index No.	P to P
Motors			
M1	Tray	20	B8
M2	Upper Lift	3	E8
M3	Lower Lift	18	F8
Sensors			
S1	Upper Lift	2	F8
S2	Lower Lift	19	F8
S3	Upper Paper End	13	B8
S4	Lower Paper End	14	C8
S5	Vertical Transport	12	C8
S6	Upper Paper Height 1	5	C8
S7	Upper Paper Height 2	4	D8
S8	Lower Paper Height 1	11	D8
S9	Lower Paper Height 2	10	D8
Switches			
S 1	Tray Cover	8	E8
S 2	Upper Paper Size	15	D2
S 3	Lower Paper Size	16	D2
Magnetic Clutches			
MC1	Upper Paper Feed	6	D8
MC2	Lower Paper Feed	9	E8
MC3	Relay	7	E8
PCBs			
PCB1	Tray Main	1	F5